

AT-3000 User guide



The R-3000 and G-3000 combine to make the perfect general purpose tools for cable avoidance. Their rugged construction ensures long life and reliability whilst the simple controls promote effective use with minimal training.

For those who require pinpoint accuracy and depth information, the AT-3000 add visual indication of signal strength together with a buried utility depth measurement capability.

AMPROBE®
1-305-423-7500

R-3000 Locator features

1 On/Off
Press and hold to use R-3000

2 Loudspeaker
To use in noisy environments unscrew and hold to ear.

3 Sensitivity control

4 Function switch
Selects locate mode:
Power, Radio, G-3000

5 Battery compartment
To replace batteries, open the access cover using a screwdriver or coin. Use eight LR6 or AA alkaline batteries.

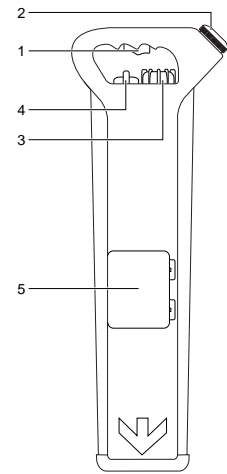

G-3000 Transmitter features

1 On/Off button
Press and hold to reduce speaker volume.

2 Direct Connection socket

3 Loudspeaker

4 Battery compartment
To replace batteries, open the access cover using a screwdriver or coin. Use four LR20 or D alkaline batteries.

5 Storage compartment
Holding Connection Cable and Ground Stake.

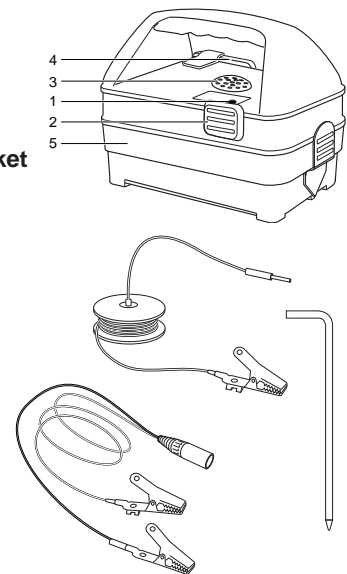

Operation of Power and Radio modes

Regularly check your R-3000 and G-3000 in all modes, over a cable which gives a response you are familiar with.

Power mode

For detection of 'Power' signals radiated by loaded cables. These are often found 're-radiated' by other, nearby conductors. Select Power using the Function switch. Press and hold the On/Off switch. Replace batteries if no initial 'bleep' is heard to confirm good battery condition.

Rotate the Sensitivity Control fully clockwise for maximum sensitivity but reduce if there is a blanket signal across the site.

Define the area to be excavated and carry out a grid pattern sweep.

Sweep holding the R-3000 upright and at your side. Continue the sweep beyond the perimeter of the area to be excavated.

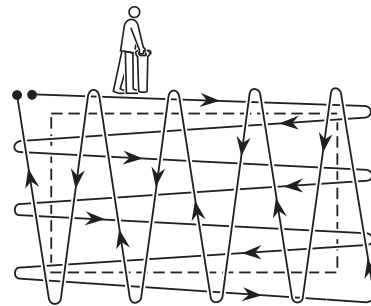

The presence of a buried conducting pipe or cable will be indicated by a tone emitted from the loudspeaker.

Keep the blade of the R-3000 vertical and move slowly backwards and forwards over the conductor, reducing the sensitivity for a narrower response. With the R-3000 use the meter deflection to aid pinpointing. Maximum meter deflection will indicate the position of the conductor.

When directly over the conductor and with the sensitivity level set for a narrow response, rotate the R-3000 on its axis until the signal minimum is found. The blade is now in line with the conductor.

Trace the conductor out of the area, marking the position as required with chalk or paint

Radio mode

For detection of radio signals originating from distant radio transmitters. These penetrate the ground and are re-radiated by buried conductors. However, they are not always present.

After completion of Power mode sweep, repeat the procedure with Radio mode selected.

WARNING

The R-3000 will detect almost all buried conductors but there are some which do not radiate any signal which the R-3000 will not detect.

There are also some live power cables which the R-3000 is not able to detect in the Power mode.

The R-3000 does not indicate whether a signal is from a single cable or from several in close proximity.

Note

The R-3000 will not provide depth information in either the Power or Radio modes.

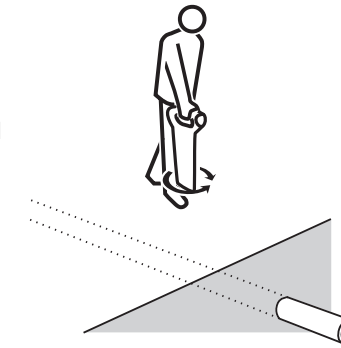

Locating with the R-3000 and G-3000

The G-3000 is used to apply a tone to a buried conductor. This signal can be traced using the R-3000 locator switched to the G-3000 mode.

Direct connection

Direct connection is the most effective form of signal application and is suitable for connection to a valve, meter, junction box or other access point.

WARNING

Connection to a power cable sheath should only be undertaken by qualified personnel.

Method

Plug the Connection lead into the G-3000 connection socket and attach the red lead to the target line. If necessary clean the connection point to ensure a good electrical contact.

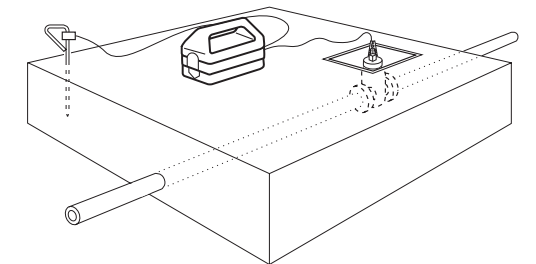

Clip the ground lead to the earth stake which should be placed in the ground 3 to 4 paces away from, and at right angles to the target line.

Alternatively the ground lead may be clipped to the rim of a valve box or manhole cover. Use the spool lead to extend the earth connection if necessary.

Switch the G-3000 on. A good connection is indicated by a drop in loudspeaker tone. If there is no tone or it is a very slow bleep, replace the batteries.

Switch the R-3000 to G-3000 mode and begin to trace the line from the point of application. Pinpoint using the same method as described for Power and Radio modes.

Induction

Induction is a convenient and quick way of applying the G-3000 signal to a pipe or cable where limited access does not permit direct connection or use of the Signal Clamp.

Place the G-3000 over the assumed position of the conductor in the orientation shown.

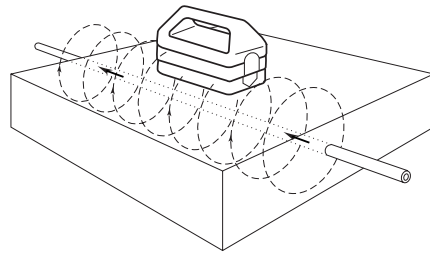

Start tracing the cable or pipe at least five paces from the G-3000 with the R-3000 in G-3000 mode. Working too close to the G-3000 may give false readings as the R-3000 will detect more signal directly from the G-3000 than from the conductor.

Do not attempt to take depth readings unless the distance between the R-3000 and G-3000 is greater than 30 paces (see "Taking depth readings using the R-3000").

Active search using Induction

Placing the G-3000 on its side swamps an area with G-3000 signal.

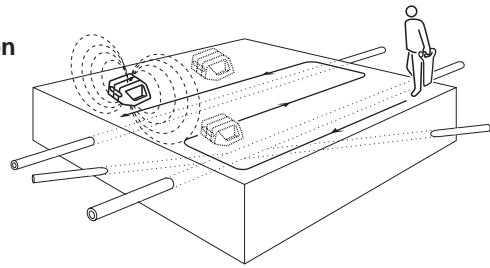

Alternatively, use a two man technique to search an area for buried utilities.

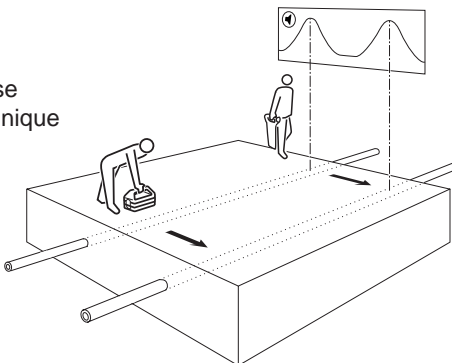

Taking line depth measurement using the R-3000

Depth measurement is only possible when using the R-3000 in the G-3000 mode.

Method
Locate the utility as described previously.

Ensure that the depth measurement position is at least 30 paces from the G-3000, especially if signal application is by Induction method.

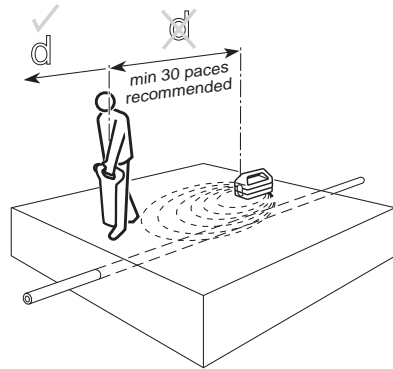

Hold the R-3000 still, vertical and at right angles to the buried line. Momentarily depress the depth button. The display will show a moving clock face followed by the depth measurement.

Taking Mouse depth measurements using the R-3000

Depth measurement is only possible when using the R-3000 in the G-3000 mode with a Mouse transmitter.

Method
Locate the main Mouse signal as previously described. Hold the R-3000 vertically and *in line* with the Mouse. Press and *hold* the depth button until 'M' appears on the display. A clock face will appear in the top right hand corner of the display while the depth calculation is made. The approximate depth to the Mouse will then be displayed on the meter.

R-3000 error codes

000 Indicates very shallow conductor

444 Indicates conductor out of range

- - - Indicates depth measurement attempted in R or P mode which is not available.

WARNING

Do not use the R-3000 depth measurement to decide if mechanical digging over buried conductor is appropriate.

Optional Accessories

Using the optional* Signal Clamp SC-3000

The Signal Clamp applies a G-3000 signal safely to a pipe or live cable of up to 76mm (3 inches) diameter, without interrupting the supply.

Method
Plug the Clamp into the G-3000 Connection socket.

Place the Clamp around the pipe or cable ensuring the jaws are closed. Switch the G-3000 on. Open and close the Clamp. If the jaws are closing correctly a drop in speaker tone will be heard.

An earth connection is not necessary but efficient signal transfer is only achieved if the target conductor is grounded at both ends. This is usually the case with power cables.

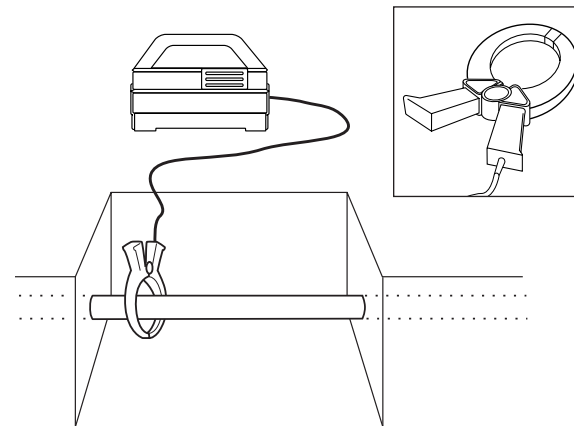

Using the optional* Mouse Signal Transmitter M-3000

The mouse is a small self-contained watertight transmitter which can be detected by the R-3000 when switched to the G-3000 mode.

Method
Replace the battery in the Mouse. Attach the Mouse to a drain rod using an appropriate connector.

Place the Mouse on the ground, set the R-3000 to G-3000 mode and, whilst holding the R-3000 in line with the Mouse, check that a signal is being received.

Insert the Mouse approximately 1m/3yd into the duct/drain and adjust the R-3000 sensitivity to receive the signal.

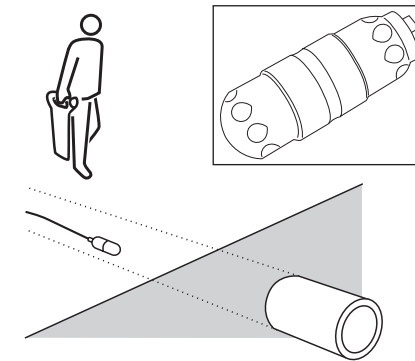

A ghost signal appears before and behind the main signal position. Reduce the R-3000 sensitivity to receive only the main signal.

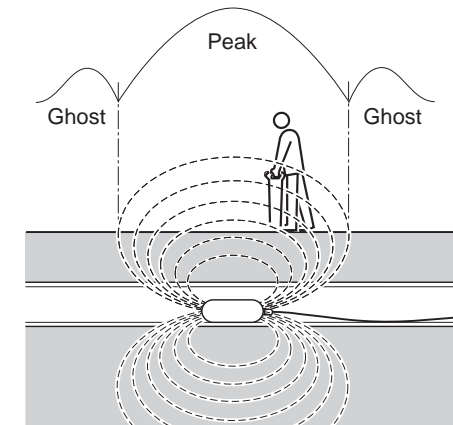

Replacements

Connection Kit CK-3000
(Includes connection cable and ground stake)

Amprobe

Tel: 305 423 7500

Fax: 305 423 7554

Technical Support:

800 327 5060